

<b>00</b>	<b>ORGANE DE BASE MOTEUR</b>
	ENGINE BASIC COMPONENT
	GRUNDORGAN MOTOR

<b>42</b>	<b>ORG. ALIMENTATION COMBUST.</b>
	GAS-OIL SUPPLY COMPONENT
	ORGAN GAS-ÖL VERSORGUNG

<b>203</b>	<b>C.S.A. " Big-Job " moteur M 32S</b>
	" Big-Job " SEMI-FORWARD CAB M 32S
	" Big-Job " KURZHAUBER M 32S

<b>00</b>	<b>42</b>	<b>203</b>	n° édition catalogue	n° de planche
1	2	3	4	5

Réservoir, filtres, tuyauteries de combustible. . . . .  
*Fuel tank, filter and lines*  
*Kraftstofftank, filter und Leitungen*

00 01

**CATALOGUE RELEVÉ AU 28-5-71**  
 C.S.A. moteur n° 10-218  
 "BIG-JOB" châssis n° 100-291

**CATALOG ACCOUNTING AS OF 28-5-71**  
 "BIG-JOB" engine n° 10-218  
 Semi-forward chassis n° 100-291  
 cab.

**KATALOGAUSSUG ZUM 28-5-71**  
 "BIG-JOB" Motor Nr 10-218  
 kurzhauber Chassis Nr 100-291

1	ORGANE DE BASF	BASIC COMPONENT	GRUND-ORGAN
2	ORGANE	COMPONENT	ORGAN
3	TYPE D'ORGANE	COMPONENT TYPE	ORGANTYP
4	N° ÉDITION	CATAL. EDITION NUMBER	NUMMER DER AUSGABE
5	N° PLANCHE	PLATE NUMBER	BILD Nr.
6	REPÈRE	MARKING	KENNZIFFER

7	N° PIÈCE	PART N°	TEIL Nr.
8	DÉSIGNATION	DESIGNATION	BESCHRIFTUNG
9	QUANTITÉ	QUANTITY	MENGE
10	CODE OBSERVATIONS	CODE OF OBSERV.	ANMERKUNGEN KODE
11	DÉTAILS OBSERVATIONS	DETAILS OF OBSERV.	ANMERKUNGEN BEDEUT.

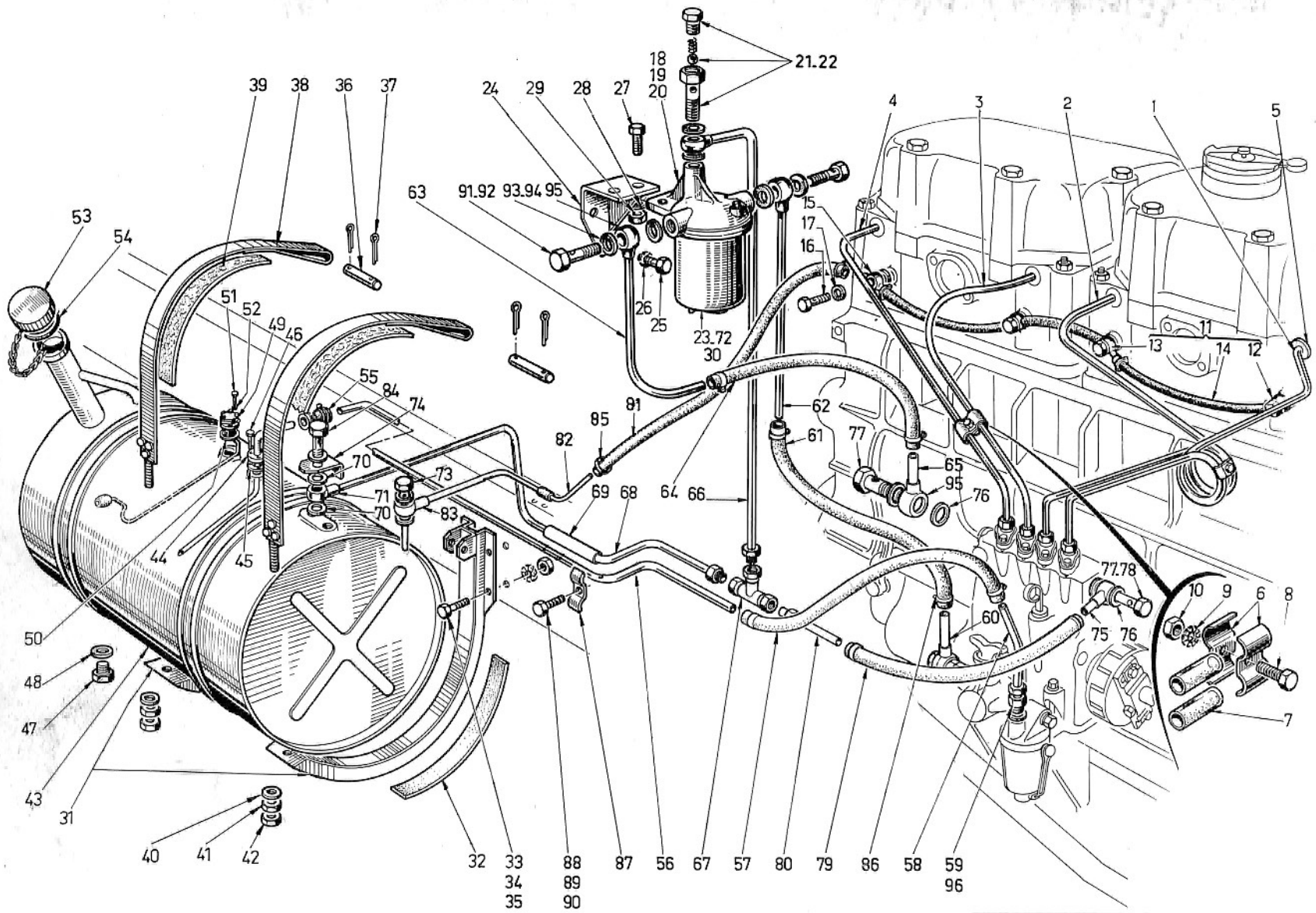

00	42	203	00	01
1	2	3	4	5

6	7	8	9	10
1	61663738	TUYAU CYL 1	1	
2	61663739	TUYAU CYL 2	1	
3	61663740	TUYAU CYL 3	1	
4	61663742	TUYAU CYL 4	1	
5	61254778	JOINT TORIQUE	4	
6	61216196	DEMI COLLIER	6	
7	61216197	BAGUE	6	
8	61802555	VIS	3	
9	61815222	RONDELLE	3	
10	61801009	ECROU	3	
11	61659146	TUYAUTERIE ASS	1	
12	61228441	RACCORD SIMPLE	1	
13	61228440	RACCORD DOUBLE	2	
14	61652051	TUYAU	1	
15	61239219	RACCORD SORTIE	1	
16	61224938	VIS CREUSE	4	
17	61815085	JOINT	8	
18	61278108	FILTRE CP 50	1	
19	61292836	FILTRE FS50M1D	1	
20	61662753	FILTRE S80SD	1	
21	61253949	SOUPAPE FIL PM	1	
22	61227995	SOUPAPE SIGMA	1	
23	61662756	CARTOUCH S80SD	1	
24	61077477	SUPPORT	1	
25	61803105	VIS	3	

6	7	8	9	10
26	61815224	RONDELLE	3	
27	61803189	VIS	2	
28	61815226	RONDELLE	2	
29	61801013	ECROU	2	
30	61213545	CARTOUCHE CP50	1	
31	61659718	SUPPORT ASS	2	
32	61227829	GARNITURE	2	
33	61803189	VIS	8	
34	61815226	RONDELLE	8	
35	61801013	ECROU	8	
36	61211618	AXE	2	
37	61819931	GOUPILLE	4	
38	61659760	SANGLE	2	
39	61227830	GARNITURE	2	
40	61815005	RONDELLE	2	
41	61400020	ECROU	2	
42	61414890	ECROU	2	
43	61657910	RESERVOIR 150L	1	
44	61274464	TUBE ASS	1	
45	61110003	JOINT	1	
46	61400121	VIS	4	
47	61216526	BOUCHON	1	
48	61238489	JOINT	1	
49	61669434	JAUGE	1	
50	61574984	JOINT	1	

10	11

10	11

00 42 203 00 01

DÉSIGNATION PLANCHE : SE RÉFÉRER AUX PAGES "SOMMAIRE"  
 PLATE DESIGNATION : REFER TO FLYLEAF  
 BILDBESCHRIFTUNG : SIEHE VORSATZBLÄTTER



6	7	8	9	10
51	61404707	VIS	3	
52	61234171	RONDELLE	3	
53	61250480	BOUCHON	1	
54	61250481	JOINT	1	
55	61077480	DURITE	1	
56	61226866	TUBE 8X10	1	57
57	61250641	DURITE	1	
58	61666803	TUBE 8X10	1	57
59	61251302	UNION	1	
60	61506509	TUBE 8X10	1	57
61	61250642	DURITE	1	
62	61659336	TUBE 8X10	1	57
63	61659337	TUBE 8X10	1	57
64	61250642	DURITE	1	
65	61506509	TUBE 8X10	1	57
66	61666763	TUBE 8X10	1	57
67	61250527	RACCORD	1	
68	61666764	TUBE 8X10	1	57
69	61222459	ISOLATEUR	1	
70	61238489	JOINT	4	
71	61216385	RACCORD	1	
72	61218600	CARTOUCFS50M1D	1	
73	61667010	PLONGEUR	1	
74	61216387	FREIN	1	
75	61506509	TUBE 8X10	1	57

6	7	8	9	10
76	61251954	JOINT	6	
77	61251960	VIS CREUSE	2	
78	61237756	SOUPAPE	1	
79	61250467	DURITE	1	
80	61236967	TUBE 8X10	1	57
81	61226563	DURITE	1	
82	61663938	TUBE 4X6	1	570
83	61231292	RACCORD	1	
84	61216386	VIS CREUSE	1	
85	61252904	COLLIER	2	
86	61225203	COLLIER	10	
87	61830727	COLLIER	2	
88	61803074	VIS	2	
89	61815223	RONDELLE	2	
90	61801010	ECROU	2	
91	61251797	VIS CREUSE PM	2	
92	61251960	VIS CREUSE SIG	2	
93	61251798	JOINT PM	6	
94	61251954	JOINT SIGMA	6	
95	61250464	RACCORD	6	
96	61205205	JOINT	1	

10	11
57	Tube à combustible (vendu au mètre) Réf. 902712 <i>Fuel tube (sold by metre) Ref. 902712</i> <i>Kraftstoffleitung (Verkauf meterweise), Nr. 902712</i>
570	Tube vendu au mètre Réf. 902710 <i>Tube sold by the metre Ref. 902710</i> <i>Rohr, verkauft als Meterware Ref. 902710</i>

10	11

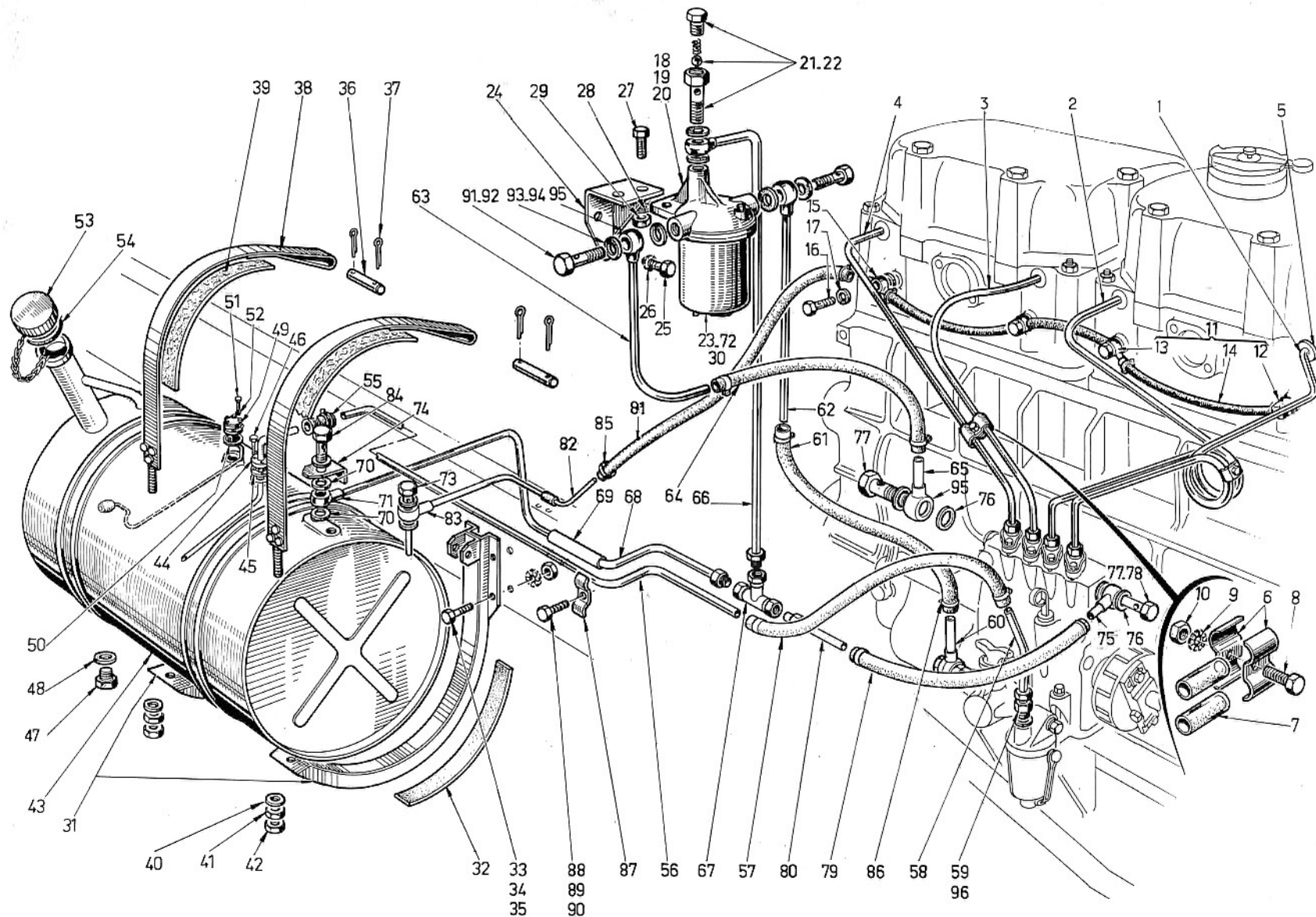

<b>00</b>	<b>42</b>	<b>203</b>	<b>00</b>	<b>01</b>
1	2	3	4	5